

-  
COMPANY PROFILE

An innovative italian lighting  
design company

**FOSCARINI**

The image features two identical, semi-transparent orange lamps. Each lamp has a wide, shallow, cylindrical shade that tapers slightly towards the top. The shade is supported by a central stem that branches into three legs, forming a tripod base. The lamps are positioned on the left and right sides of the frame, with the one on the left slightly behind the one on the right. The background is a solid, bright yellow color.

A company that makes its dreams come true.  
A technological and creative workshop that  
conceives, develops and produces not just lamps  
but pure emotions, in collaboration with many  
other designers from around the world.  
A company that is free, passionate,  
unconventional and right at the heart  
of the industry in which it thrives. This is Foscarini.

A designing and technological tour de force, Foscarini explores  
an entire world of materials and solutions. Their research atelier  
experiments, free of any mental barriers or technical restraints  
through flexible, efficient and high quality production, while the  
sales and logistics organisation distributes with equal care  
all over the world the smallest table lamp to the largest lighting set.  
Foscarini: a special personality in the world of lighting.

– Prima sede Foscarini, Murano  
/ *First Foscarini headquarter,  
Murano*



– Compasso d'Oro, 2001



– (in senso orario) lo showroom,  
nel magazzino il controllo  
qualità, la mensa, vista degli uffici  
/ *(clockwise) showroom, quality  
controls, cafeteria, offices*



– Sede Foscarini,  
Marcon (Ve) / *Foscarini  
headquarter, Marcon  
(Ve)*

Foscarini's headquarters are housed in an architect-designed, contemporary building in sync with its corporate mission to provide cutting edge design and sales service with logistics and warehousing providing total quality control.

In the mid 1990's, Foscarini's wish to provide design service to international markets led to a strategic move from the island of Murano to Marcon, on the Venetian terra firma. Here, they built a new facility, whose modern aesthetic is aligned with Foscarini's creative corporate spirit.

They are certified UNI EN ISO 9001 which guarantees the quality of all the company processes, from designing to production, to customer services. With the same spirit that provides new ideas in lighting design, Foscarini also creates its own more efficient programs for customer and partner communication.

For instance, My Foscarini, a proprietary it platform, allows 24/7 connectivity to current product availability, order placement and shipment tracking.



# Why are Foscarini lamps so different from each other, yet share common concepts and values?

Foscarini focuses on developing new products but chooses only to put into production those that express new ideas.

While inspiration is always valued, Foscarini's development phase sometimes takes years of progressive research to analyze materials, shapes, processes and operating modes that sometimes lead to results drastically different from the initial concept.

This is why Foscarini lamps are so innovative yet built to weather the whim of trends and become true classics.

Over 50 models, more than 20 different materials and more than 30 designers come together to form a collection of individual lamps, each with a unique story to address a need with striking beauty.

With a surprising visual simplicity, often the result of complicated but concealed technology, Foscarini's lamps have an impeccable logic that goes beyond the conventional and the commonplace.

From its founding, in the early 1980's, Foscarini has stood out from other Murano glass lamp manufacturers because it did not have its own furnace. Not tied to a particular manufacturing process, Foscarini could pick the most suitable supplier for each project in question.

This freedom led Carlo Urbinati and Alessandro Vecchiato, first as designers then as the company managers, to experiment with materials and processes other than blown glass. As a result, the collection could flexibly respond to a changing world as new materials and technologies became available.



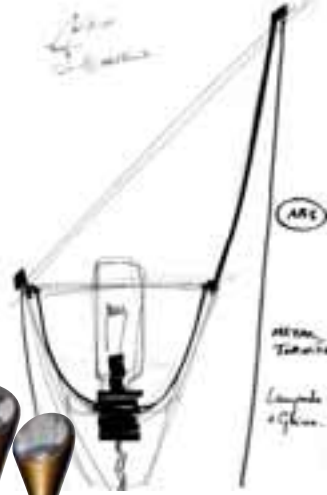

*MITE*  
- Sviluppo del progetto e lavorazione del diffusore / *Project development and making of the shade*

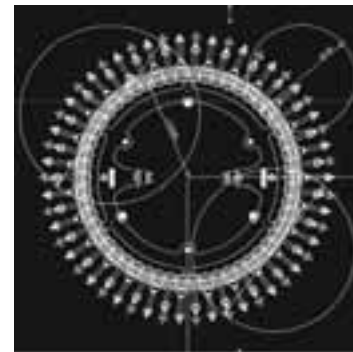
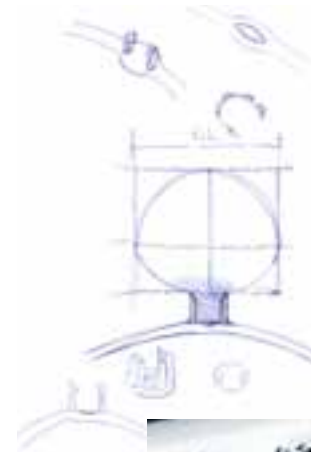

*CABOCHE*  
- Sviluppo del progetto e studio delle sfere / *Project development and study on the spheres*



*TROPICO*  
- Studio del modulo / *Study on the module*

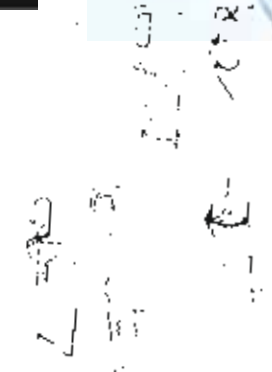

*TRESS*  
– Sviluppo del progetto e studio  
del nastro / Project development  
and study on the ribbon

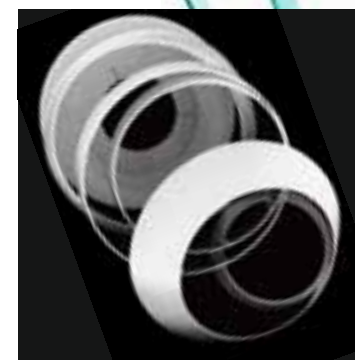
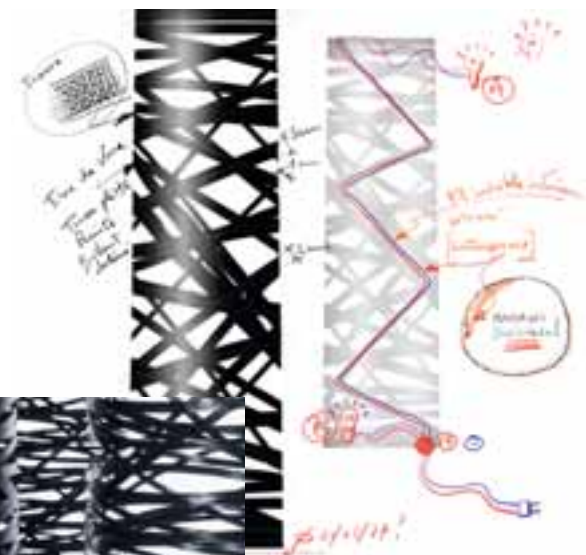

*LE SOLEIL*  
– Dettagli del diffusore.  
Studio del progetto  
/ Shade details. Project  
study

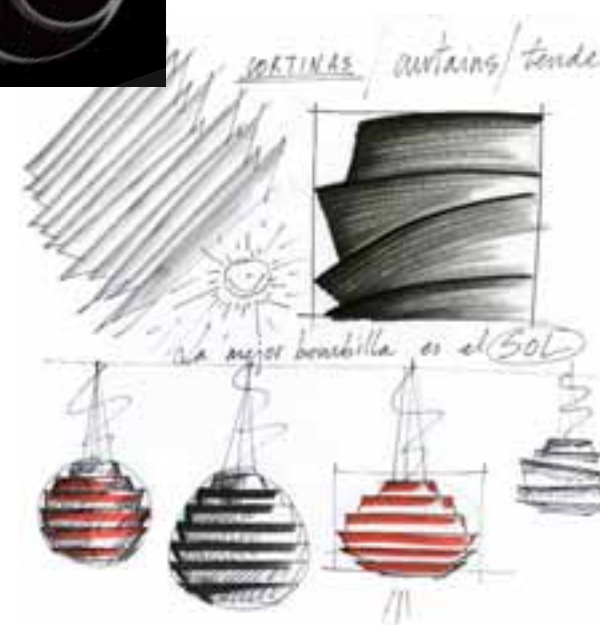
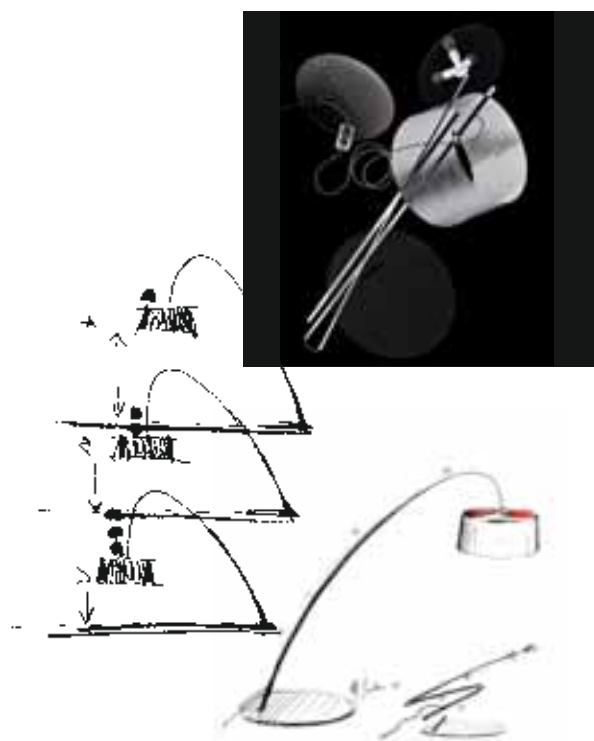

photo: Schöner Wohnen / Jeanette Schauer

*TWIGGY*  
– Studio e particolari del progetto  
/ Project study and details





*BINIC*  
- Schizzi e dettagli della lampada smontata /  
Drawings and details of the lamp

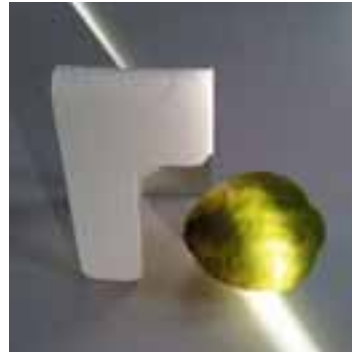

*TUA*  
- Studio del progetto /  
Project study

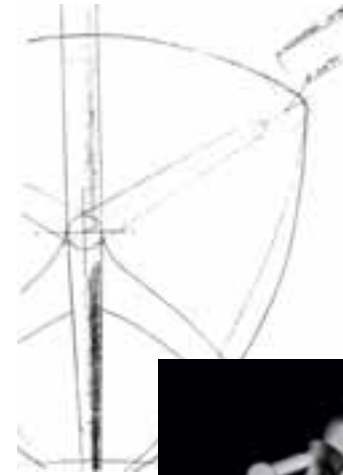
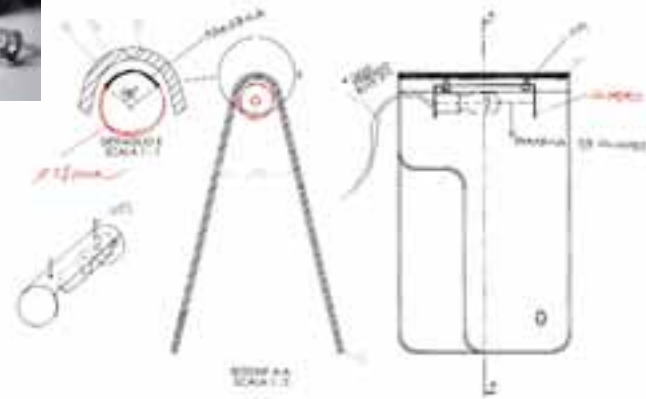

*LUMIERE*  
- Lavorazione del diffusore in vetro soffiato /  
Manufacture of the blown glass shade

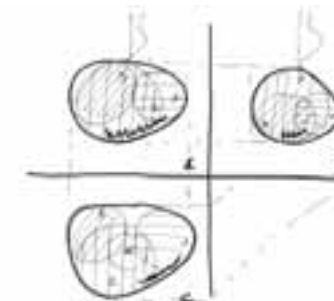
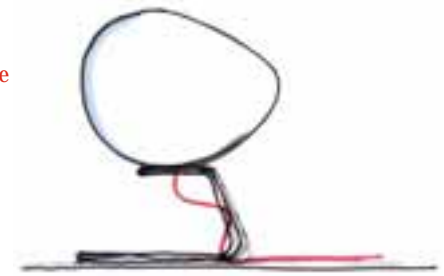

*GREGG*  
- Studio della forma e lavorazione del diffusore /  
Study on the shape and making of the diffuser

**1990** Folio, Lumiere **1992** Orbital **1993** Bit, Havana, Quadro **1994** Circus **1995** Lightweight **1996** Dolmen, Double, Dress, Esa **1998** Cross, Qua, Shape, Totem **2000** Bubble, Cocò, Mite, Tite, Supernova, **2001** Affix, Lite, Manta, Tutù **2002** Blob **2003** Bague, Ellepi, Kite, O-space, Yet **2004** Gea, Giga-Lite, Mega-Kite **2005** Big Bang, Caboche, Uto **2006** Twiggy **2007** Allegro, Easy, Empire, Fields, Gregg, New Buds, See you, Tosca, Wagashi **2008** Tress, Tropico **2009** Flap, Fly-Fly, Allegretto, Le Soleil, Lumiere XXL, Wave **2010** Aplomb, Bahia, Tua, Troag, Binic, Lumiere XXS

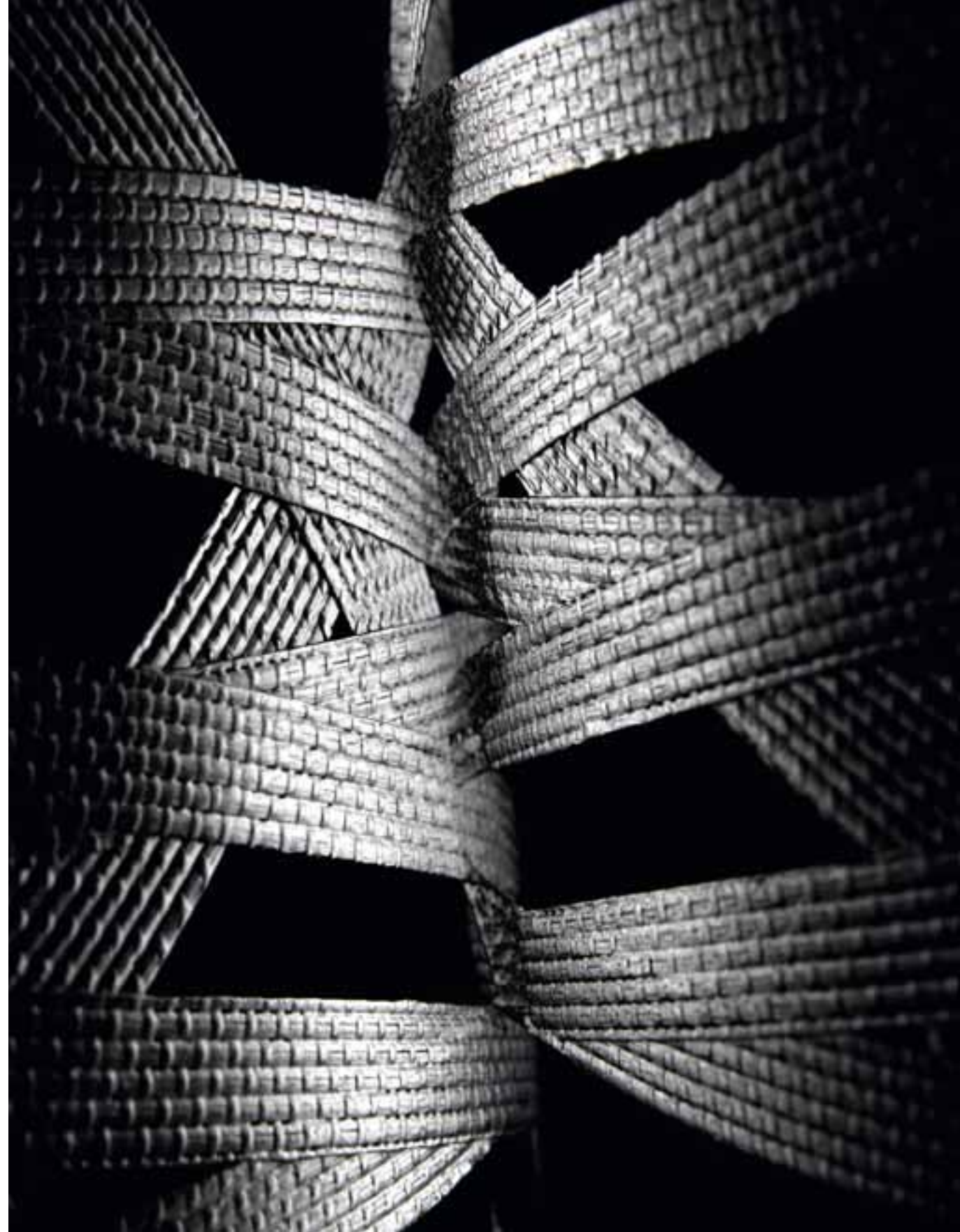

— *LUMIERE XXL+XXS* design  
Rodolfo Dordoni, 2009/2010



Maurizio Baruffi, Valerio Bottin,  
Aldo Cibic, Roberto De Santi,  
Designwork, Tom Dixon, Rodolfo Dordoni,  
Jozeph Forakis, Enrico Franzolini,  
Gianpietro Gai, Massimo Gardone,  
Eliana Gerotto, Giulio Iacchetti,  
Vicente Garcia Jimenez, Studio Kairos,  
Defne Koz, Lagranja Design,  
Ferruccio Laviani, Giovanni Levanti,  
Lievore Asociados, Paolo Lucidi,  
Alessandra Matilde, Luca Nichetto,  
Atelier Oi, Roberto e Ludovica Palomba,  
Luca Peveri, Karim Rashid,  
Prospero Rasulo, Marc Sadler,  
Pio e Tito Toso, Patricia Urquiola,  
Ionna Vautrin, Marco Zito



Design first and foremost. Thought before shape. The spirit of the project guides the choice of material.

These are the distinguishing traits of a huge “work in progress” that teams up great maestros and young talents.

Foscarini has so many designs, both from young designers as well as established names, which have gained much notoriety. For example, Rodolfo Dordoni's Lumiere has become one of Foscarini's best-sellers, a contemporary, or rather universal revamping of a classic blown glass lamp. Ferruccio Laviani's Orbital “sculpture lamp” was so impressive it was chosen as the subject of a stamp issue dedicated to design. Jozeph Forakis conceived Havana, another international icon for the company and the first Foscarini lamp made with a material other than glass, now part of the permanent collection at the New York MoMA. Marc Sadler, the undisputed master of contemporary design, produced Mite and Tite which won the 2001 Compasso d'Oro. These two lamps were developed after years of research and tests, in an innovative mixture of fibreglass and carbon or Kevlar®. And yet more

world-wide successes, include Caboche by Patricia Urquiola and Eliana Gerotto, O-Space by Luca Nichetto and Giampietro Gai, Twiggy and Tress by Marc Sadler, Gregg by L+R Palomba, Le Soleil by Vicente Garcia Jimenez, and the recent Aplomb by Lucidi and Pevere and Binic by Ionna Vautrin... Every Foscarini lamp has a special story to tell.

Foscarini's flexibility and desire to collaborate with designers have enabled it to develop custom projects by grouping their lamps in large numbers, responsive to the most diverse contemporary settings.

The company is willing to produce custom products simply by changing standard finishes and compositions. Foscarini also devises specific solutions for large spaces in the form of light sculptures that are the result of the creative assembly of standard lamps. This has given rise to lighting events, including Fiber Evolution in collaboration with Marc Sadler and Tropico with Giulio Iacchetti, which have travelled across the design capitals of Europe and the U.S.A

This acquired experience led to the coining of a program called Foscarini Evolution in 2010 to communicate the company's ability to collaborate with designers, experiment with diverse materials and exploit the infinite composition potential of standard models to surprising effect.



- *ALLEGRO* al ristorante  
Le Bombarde, Arsenale (Venezia,  
Italia) / *Allegro* at Le Bombarde  
restaurant, Arsenale (Venice, Italy)

– CABOCHE al Motel One, Dresda  
(Germania) / Caboche at Motel One,  
Dresden (Germany)  
pag. 27 Raccolta di progetti contract  
/ Contract projects collection

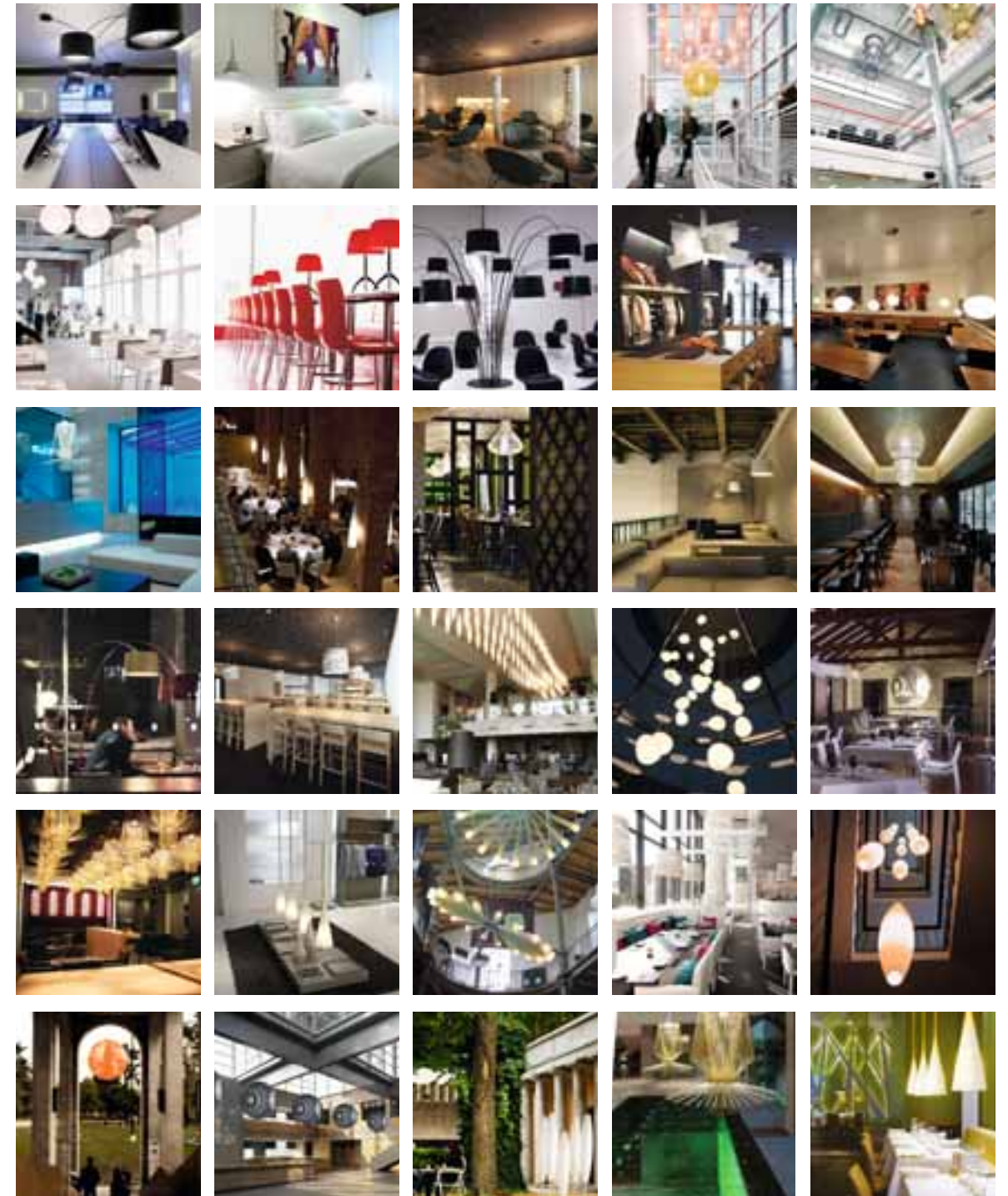

Casamica, Domus, Case da Abitare, Grazia Casa, Abitare, DCasa, Elle Decor, National Geographic, l'Espresso, Home Germany, A&W, AIT, Elle Decoration Germany, Home Austria, Ideales Heim, Espaces Contemporains, Ideat, Elle Decoration France, Archicr e, Arquitectura y Dise o, Casaviva, Projecto Contract, On Dise o, Wallpaper, Rum, Bo Bedre, Elle Interior, Skona Hem, Eigen-Huis, VT Wonen, De Architect, A+, DAMn, Wohnrevue, Feeling Wonen/Gael Maison, Residence Svezia, Drome Magazine



As unmistakable as the Foscarini lamps themselves, the corporate image is the result of a creative task akin to the designing of its products, to explore new approaches and stir further emotions.

From advertising to events, publishing and the web, Foscarini's "communication design" uses an extensive range of coordinated tools.

The products are illustrated in catalogues targeted to different types of customer: the Collection Book is a general catalogue providing details of the origins, inspiration, development and general backstage information for the Foscarini product range; the Technical Book, provides technical information required for sales and installation; while the Works catalogue is a collection of interpretations for the contract and collective industry featuring models from the Foscarini collection; the News catalogue features the year's new products. Foscarini advertising highlights the iconic value of its products, in spreads featured in the leading international architecture and furniture magazines.

The website is a dynamic and interactive tool to inform the public and industry specialists of any news in the Foscarini world: from the products, to the cultural initiatives and events.

An important strategy communicating Foscarini's corporate identity is through participation in the major trade fairs and events in the design world with installations that convey the value and personality of the brand. This presence is not merely commercial but creative, poetic and thrilling at the same time.

– Copertina e pagine interne  
dei cataloghi aziendali / *Company  
catalogues cover and pages*



01 – Collection  
book



02 – Works



03 – Technical  
book



04 – News



*NEW MEDIA*  
– Sito internet e applicazione  
iFoscarini / *Website  
and iFoscarini application*

– *Infinity*, Milano Designweek 2009.  
Installazione Vicente Garcia Jimenez,  
video Massimo Gardone, musiche  
Francesco Morosini. Evento selezionato  
dall'ADI per il Design Index 2010  
/ *Infinity, Milan Designweek 2009.*  
*Installation design Vicent Garcia Jimenez,*  
*video Massimo Gardone, music Francesco*  
*Morosini. Selected by ADI, for the Design*  
*Index 2010*

a destra – Installazione *Foscarini Evolution*,  
Designer's Saturday 2010, Langenthal  
(Svizzera) / *Foscarini Evolution installation*  
*Designer's Saturday 2010, Langenthal*  
*(Switzerland)*



Foscarini contributes to spreading and supporting design culture: from the presence of its products at the Art and Architecture Biennale in Venice, to its inclusion in the collection of New York's MoMA, the Milan Triennial Exhibition and a large number of other international museums, to the launching of new publishing initiatives.

The positive experience with Lux magazine, which from 2002 to 2008 was the spokes piece for new ideas, materials and creative stimuli, led to the creation of "INVENTARIO – Everything is a project". It is not intended as an advertising vehicle for Foscarini, but rather as a genuine magazine-book, directed by Beppe Finessi, architect and university lecturer and distributed on an international scale in the best bookshops and major museum bookshops. A free and illuminated look at the universe of design and the world we live in: design, architecture and art, it also contains strange life stories, analyses

of objects created by nature and other freestyle topics. Without feeling constrained, without ties to the Foscarini brand and its products: in the belief that everything that surrounds us, every moment we experience is a project to be shared with others. Through its support of INVENTARIO, Foscarini conveys its own values and looks forward attentively and curiously, to the pure pleasure of experimenting, innovating, creating: as always in the spirit of this company and of the people who work within it or with it every day.

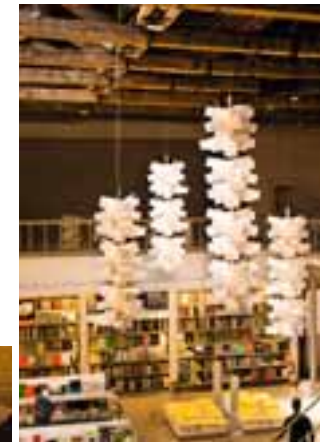

– La Biennale di Venezia con lampade Foscarini: Uto, Tropico, Havana e BigBang Evolution all'Arsenale / La Biennale di Venezia with Foscarini lamps: Uto, Tropico, Havana and BigBang Evolution at the Arsenale



– “INVENTARIO-Tutto è progetto”  
presentazione alla Biennale  
di Architettura di Venezia, 2010  
/ “*INVENTARIO-Everything  
is a Project*” preview at Biennale di  
Architettura 2010, Venice



Home page del sito / Home page of  
[www.inventario-bookzine.com](http://www.inventario-bookzine.com)



37,4

Consolidated turnover for the year 2010: 37.4 million Euros

8,5%

Communication: 8.5% of turnover invested in brand promotion and communication activities, a third of which in cultural activities.

8%

Research: 8% of turnover invested in research and development of new products

77%

Export rate: 77% of turnover

30

Materials: the lamps in the Foscarini collection are made with over 30 different materials

5

Logistics: 5 warehouses across the world, with the aim of delivering as quickly as possible, from 2 to 5 days, all over the globe

88

Distribution: direct, in 88 countries world-wide

2800

Sales points: 2,800 shops, specialising in lighting or furniture

65

Number of employees: 65, average age 35

1996

Company Quality Certification: UNI EN ISO 9001, awarded in 1996, among the first in the industry

## 10. TIMELINE

1981	Foscarini Spa set up on Murano island (Venice).	2000	The MITE and TITE, lamps developed in conjunction with <i>Marc Sadler</i> are launched. The same year, Foscarini launches its first corporate identity communication project.	2009	Foscarini and Diesel sign a licensing deal, as part of the “Home Collection” furniture and lifestyle project. This partnership gives Foscarini the opportunity to liaise with a new target and explore new lifestyles and furnishing trends, through a collection conceived by Diesel for its own target: “ <i>Successful Living from Diesel with Foscarini</i> ”.
1983	First collection of lamps designed by <i>Carlo Urbinati and Alessandro Vecchiato</i> .				
1985	First collection in collaboration with external designers: WASSILY OFF THE WALL by <i>Adam Tihany and Joseph Mancini</i> .	2001	Foscarini and <i>Marc Sadler</i> , thanks to the MITE and TITE lamps, are awarded the Compasso d’Oro for “ <i>the bold technological innovation</i> ”.		
1988	<i>Carlo Urbinati and Alessandro Vecchiato</i> become the company owners and managers.	2002	Lux magazine, Foscarini’s first publishing experience, starts off.	2010	Foscarini presents a new publishing adventure, mid way between a book and a magazine, called “INVENTARIO – Everything is a project”.
1990	<i>Rodolfo Dordoni</i> designs LUMIERE, Foscarini’s first major success.	2003	The new Foscarini facility is inaugurated in Marcon (Venice).		
1992	ORBITAL, <i>Ferruccio Laviani</i> ’s debut lamp, is the first Foscarini lamp made of industrial glass.	2005	CABOCHE, designed by <i>Patricia Urquiola and Eliana Gerotto</i> , inaugurates a successful season for Foscarini, with models such as TWIGGY <i>Marc Sadler</i> – 2006, GREGG		
1993	HAVANA, designed by <i>Jozeph Forakis</i> , is the first Foscarini lamp made of a material other than glass, namely polyethylene.	2007	<i>L+R Palomba</i> –2007, TRESS <i>Marc Sadler</i> –2008, LE SOLEIL <i>Vicente Garcia Jimenez</i> –2009. These products can truly express their innovative and design culture contents, owing also to the company’s accrued experience in all fields: from technology, to communication, to logistics.		
1994	Foscarini moves from Murano island to Marcon, on Venetian terra firma.				
1996	The company is among the first in the industry to receive UNI EN ISO 9001 quality system certification.	2008	Foscarini becomes the official sponsor of the Venice Biennale Exhibition.		

FOSCARINI SRL via delle Industrie 27

30020 Marcon / Ve - Italy

T +39 041 5953811 F +39 041 5953820

e-mail: [foscarini@foscarini.com](mailto:foscarini@foscarini.com)

[www.foscarini.com](http://www.foscarini.com)

